

Instant Lab Universal **USER MANUAL**

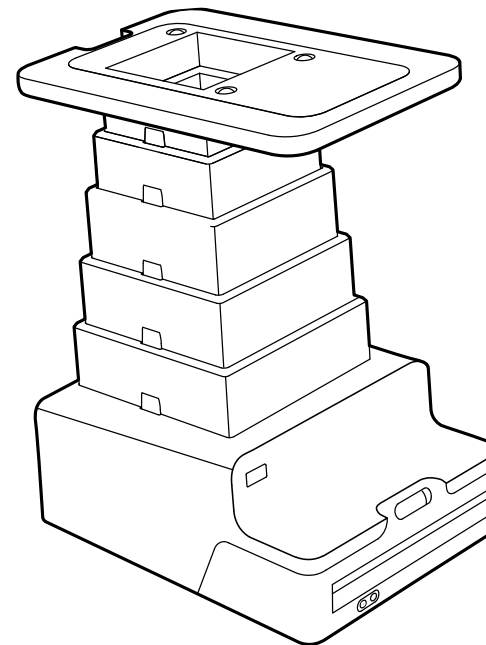

Please be sure to read through this manual before using the Instant Lab Universal. Keep for future reference. For updated information, video tutorials and more, please visit the-impossible-project.com/instantlab

PARTS OF THE INSTANT LAB UNIVERSAL

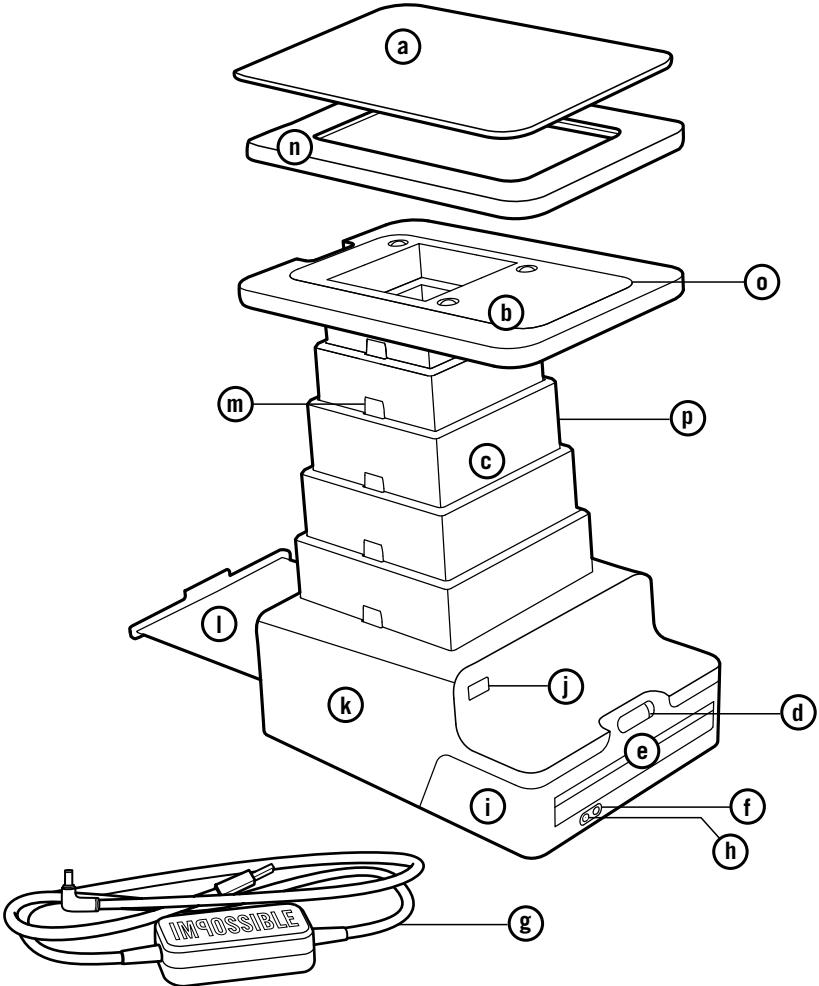

- a Cradle cover
- b Universal Cradle
- c Tower
- d Film Door Latch
- e Frog Toungue
- f Power Indicator LED
- g USB Charger
- h USB Power Connector
- i Film Door
- j Eject Button
- k Film Processing Unit (FPU)
- l Shutter Slide
- m Tower section tab
- n Adaptor
- o Cradle Mount Marks
- pCradle Mount

HOW TO USE THE INSTANT LAB UNIVERSAL

1

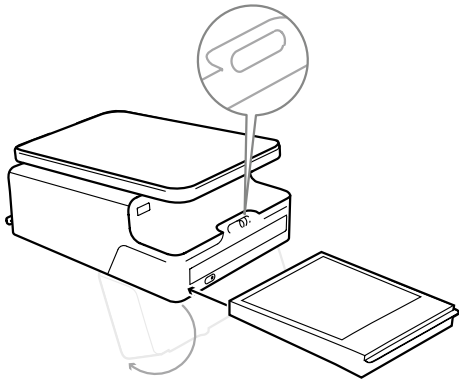

2

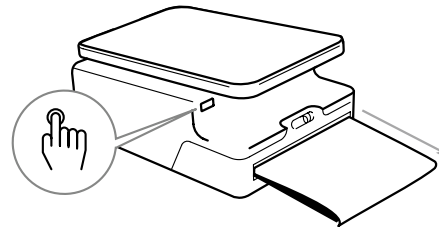

3

klik!
klik!
klik!
klik!
klik!

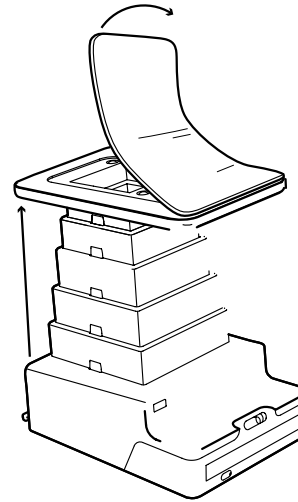

4

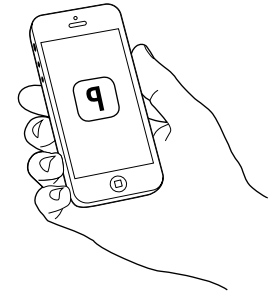

5

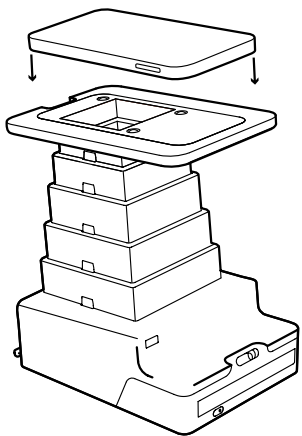

6

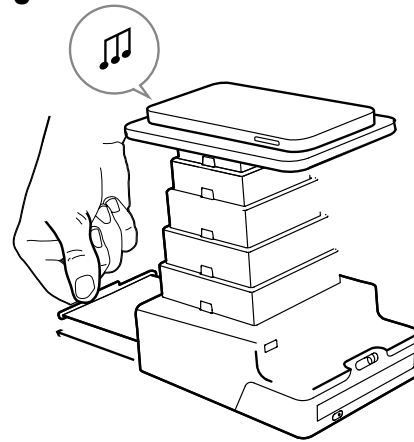

7

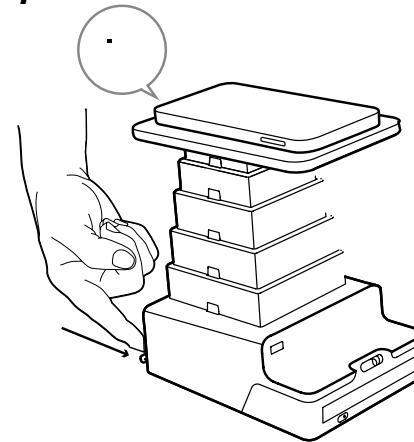

8

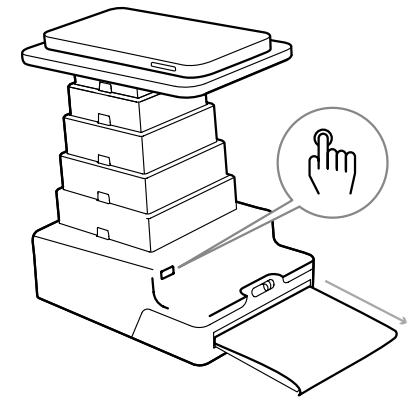

CHANGING THE CRADLE

1

klik!
klik!
klik!
klik!

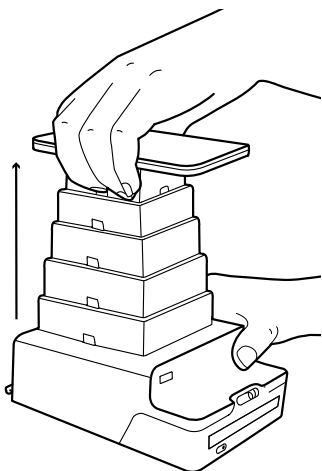

2

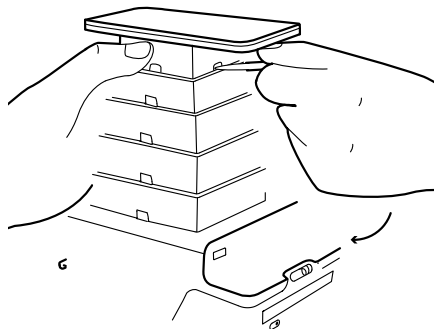

3

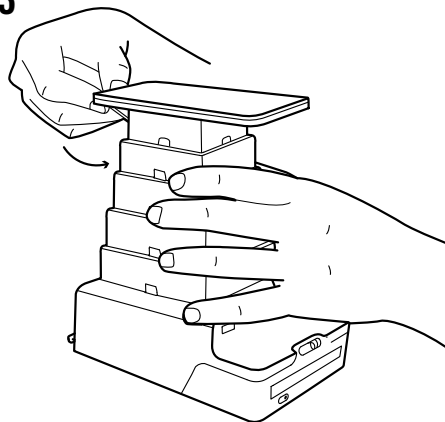

4

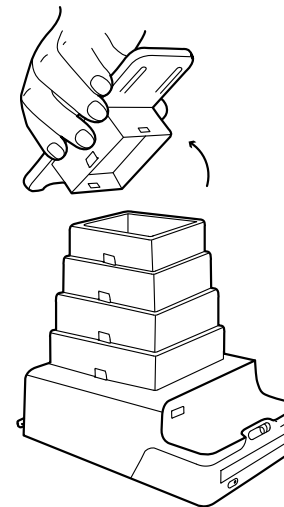

5

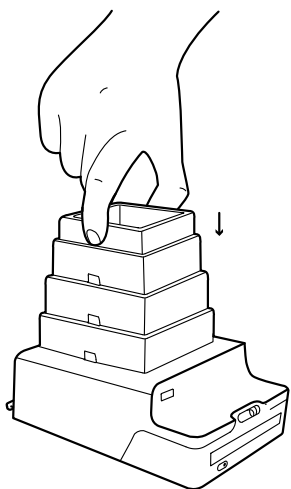

6

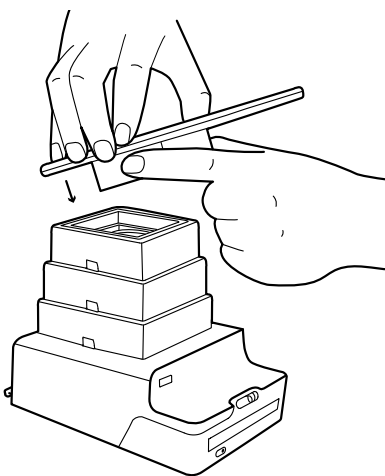

7

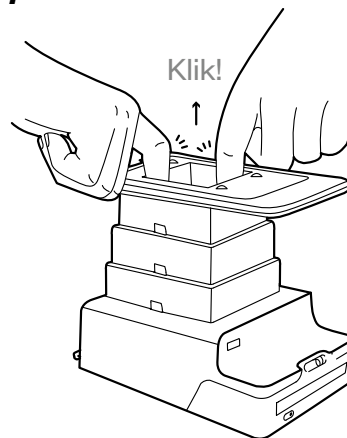

8

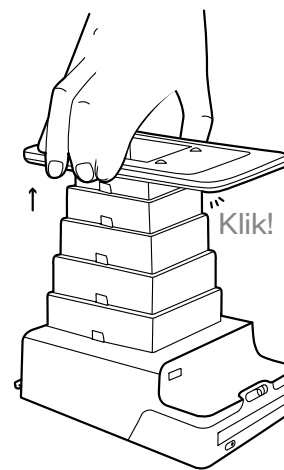

Many of us take photos with our smartphones or tablets, but the images rarely escape our screens. That's why we came up with the Instant Lab Universal, a camera that allows you to transform any digital image on your smartphone or tablet into a real, tangible, instant analog photo.

CONTENTS

ENGLISH

Safety Information

Preparing and Using the Instant Lab
Universal

Troubleshooting & FAQ

Customer Support

SAFETY INFORMATION

SAFETY

CAUTION – RISK OF ELECTRIC SHOCK – DO NOT OPEN/ DISASSEMBLE THE MOTORIZED ROLLER SYSTEM.

- Do not disassemble the device. Incorrect reassembly can cause electrical shock if the device is used again.
- Do not immerse the device in water or other fluids.
- Do not operate the device in a high humidity environment or very dusty environments.
- Do not attempt to tamper with, adjust, or remove the battery and/ or the electronics located below the rollers behind the device's film door.
- Do not attempt to remove the door itself as it is connected electronically to the body of the device. Doing so is unsafe, will likely damage your device, and will void your warranty.
- Do not insert metal objects into the product.
- Do not insert any objects into the rollers or gears.
- Keep small children and infants away from the device to avoid them being injured by the device's moving parts.

- Do not use or store the product near any heat source or any type of equipment that generates heat, including stereo amplifiers.
- Do not use the device near flammable or explosive gases.
- Do not charge the device if you notice any unusual odors, noise or smoke.
- Do not attempt to disassemble the film's battery or modify it in any way. If battery fluid gets into your eyes, immediately rinse your eyes with fresh cold running water and seek medical attention immediately.

BATTERY AND CHARGER

- This device uses a custom Impossible lithium ion battery that is non-removable and mounted below the roller system. No other type of battery can be used. Battery replacement can only be done by Impossible Service Centers. The battery will provide many years of service if properly used.
- Power consumption varies depending on the environment the device is used in and how the device has been stored. Usually the battery will power the processing of dozens of film packs with one single charge.

- Once the battery energy level falls below a certain level, the device will no longer process film. The LED will blink and signal when it needs to be recharged. This is to avoid a photo from getting stuck as it's being processed through the roller system.
- The rechargeable battery is not fully charged at the time of purchase. Charge the battery fully with the provided Impossible USB Charger. This usually takes 1 – 2 hours (can vary on usage).
- The supplied battery charger is ONLY for the Instant Lab Universal. Do not charge any other type of battery with the supplied charger as this could cause leaking, overheating, explosion or fire.
- The supplied battery charger has been tested and certified to work with the Apple iPhone power adapter. While it can be used in other USB ports, e.g. computers, USB power adapters, TVs, cars etc. Impossible can not guarantee correct operation.
- When the device is no longer in use, please recycle it properly.

USAGE ENVIRONMENT

- To protect the high-precision technology contained in this product, never leave the device in the following environments for an extended period of time: high temperature (+40°C/104°F), high humidity, places with extreme changes in temperature (hot and cold), direct sunlight, sandy or dusty environments such as beaches, damp places, or places with strong vibrations.
- Do not drop the device or subject it to severe shocks or vibrations.
- Do not push, pull or press on the lens.

PREPARING AND USING THE INSTANT LAB UNIVERSAL

COMPATIBLE HARDWARE

The Instant Lab Universal requires high-resolution smartphones and tablets (with approx. 300 PPI displays) using version 3 or higher of the Impossible Project App for iOS and Android. For a full list of compatible devices, visit: the-impossible-project.com/instantlab. Alternatively, contact Customer Support: service@the-impossible-project.com. From here on, they will be referred to as 'smartphone' or 'device'.

COMPATIBLE FILM

Impossible Color and Impossible B&W 600 and SX-70 film. The Instant Lab Universal also works with original Polaroid film made for classic Polaroid 600 and SX-70 cameras.

POWER SUPPLY

Please charge your Instant Lab Universal fully before first use. Plug the USB Charger **(g)** into the Power Connector **(h)** on the Instant Lab Universal and the USB plug into your charger, such as your iPhone charger, laptop or PC's USB socket. Charging usually takes between 1 – 2 hours, a full charge can take up to between 6 - 8 hours. To prevent any damage to the battery, charging occurs slower in the first 15 minutes and increases incrementally as time progresses.

The red LED **(f)** switches off as soon as the battery is fully charged. The rechargeable Li-ion battery will typically power the processing of dozens of film packs with one single charge.

When the Instant Lab Universal runs out of power, it will cease to run upon pressing the eject button and the LED indicator will flash red.

① DOWNLOADING THE IMPOSSIBLE PROJECT APP

Download and install the Impossible Project App to your device. Search for 'Impossible Project' in your device's app store.

② LOADING THE FILM

Slide the film door latch **(d)** to open the film door. Push the film cassette all the way in, with darkslide up and the plastic base at the bottom. Close the film door.

Note Please check individual film packaging for development time, handling and storage details.

③ EJECTING THE DARKSLIDE

Press and hold the eject button **(j)** for one second to eject the films darkslide.

Note: There is only one darkslide per pack of film. Only press the eject button once to remove the darkslide.

④ EXTENDING THE TOWER AND REMOVING THE CRADLE COVER

Pull the tower **(c)** until all 5 sections of the tower have clicked firmly into place. Remove the cradle cover that's protecting the lens.

⑤ USING THE IMPOSSIBLE PROJECT APP

The Instant Lab Universal comes with a removable adaptor **(n)** for iPhone 4, 4s, 5, 5s, 5c and iPod Touch fifth generation. For all other devices, including iPhone 6, 6 Plus, iPad and Android-operating devices, you will need to remove the adaptor. Remove the adaptor by pulling it from the cradle. You can re-attach the adaptor by pressing on the cradle and ensuring all four corners have 'clicked' into place around the edges. Ensure that the small cut-out for iOS device volume control is to the right of the two rubber touch points on the cradle.

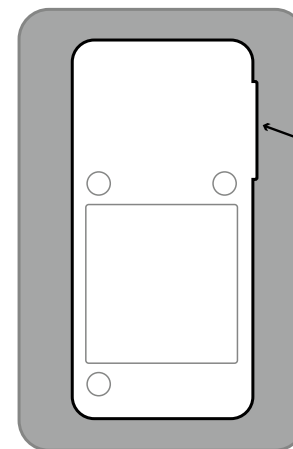

Cut-out for iOS device volume control

⑥ USING THE IMPOSSIBLE PROJECT APP

Launch the Impossible Project App on your device. You'll be given the choice of selecting either the old 'Instant Lab' or the 'Instant Lab Universal'. Choose 'Instant Lab Universal' from the menu and follow the on-screen and optional audio instructions to choose and edit your image. You can switch the type of lab being used by tapping on the settings cog in the top right of the Instant Lab screen.

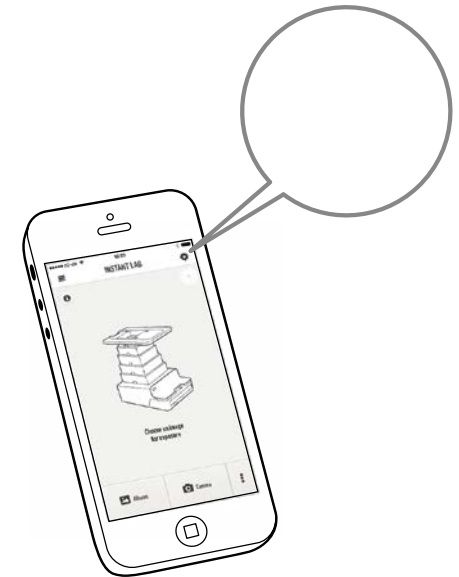

⑦ STARTING THE EXPOSURE

When ready, place your device on the Universal Cradle with screen face-down and the flash facing up towards you. The top of your device should point in the same direction as the direction your photo leaves the Instant Lab Universal. Once on the cradle, you will hear a sound to indicate a successful connection, or one that indicates a failure. Some devices will also use the flash to indicate the successful connection. When you hear the 'success' sound and you see the flash, pull the shutter slide ① all the way out. Do this within 5 seconds of hearing the success sound.

Note iPod and most Android devices will sound an alert instead of the flash.

⑧ FINISH THE EXPOSURE

When you hear the shutter camera sound (in some devices, the device's flash will also go off), push the shutter slide ① back in. Once the shutter slide is back in, you can safely remove your device off the cradle.

⑧ EJECTING THE PHOTO AND HANDLING IT CORRECTLY

Press and hold the eject button ① to eject your instant photo. With older generations of Impossible film (for example: early editions like Silver Shade and Generation 1.0), you will need to shield your photo from light during development.

For Generation 2.0 'no shield' film, you can watch your photo develop without shielding the image. See individual film packaging for details.

⑨ AFTER USE

Remove your device and replace the cradle cover ① to protect the lens. Press tabs ① on either side of each tower section to collapse the tower.

Cleaning the Instant Lab Universal

Always unplug the Instant Lab Universal from the power adaptor before cleaning.

Exterior

Wipe gently with a soft cloth. If the Instant Lab Universal is very dirty, soak the cloth in mild soapy water and wring well before use. Wipe the Instant Lab Universal with a damp cloth and then dry with a dry, clean cloth.

Roller System When cleaning the rollers, use a moist cotton swab or cloth. Do not use a paper tissue as this could get stuck between the rollers. Using a small amount of either warm water or alcohol, press the swab gently onto the rollers and press the eject button, which will turn the rollers. Do not turn the rollers forcibly by hand! Repeat several times until clean. Do not use an excess amount of water or alcohol as fluid may drip onto the electronics and damage them.

Lens Dust can be removed with a blower brush. Fingerprints can be removed by breathing on the lens and then wiping it with a lens cloth or tissue. Persistent dirt can be removed by applying a small amount of lens cleaning fluid to the cloth.

Note Mold may form on the lens surface if the lens is left dirty.

Charger Wipe gently with a soft, dry cloth.

Note Do not use strong solvents such as benzene or alcohol or a chemically treated cloth on parts other than the metal rollers.

Storing the Instant Lab

Do not leave the Instant Lab Universal in an environment with high temperatures (40°C / 104°F or more) or low temperatures (-10°C / 14°F or less.) Failure to do so may impact the battery life.

Do not use the Instant Lab Universal in the rain or allow water to enter the device. Do not pour water over the Instant Lab Universal.

When storing the Instant Lab Universal for extended periods, keep it in a cool, dry place that is well ventilated. The battery will lose its power within a period of several months. It is recommended that you recharge the battery every 3 – 5 months to extend the battery life.

Note Do not store the Instant Lab Universal in direct sunlight, in hot vehicles or near heat sources. Avoid leaving the device in places where chemical products are handled as this may result in corrosion.

TROUBLESHOOTING & F.A.Q.

The Instant Lab Universal won't eject my photo

Make sure that your Instant Lab Universal is charged; the Power Indicator LED will blink red if it doesn't have enough power to operate. Also be sure you press and hold the eject button firmly for 1 second. If the processor runs when you press the eject button but no film is ejected, make sure you have not already used up all the photos of your film pack (each Impossible film pack contains 8 photos).

My photo turned out partially/completely black

Make sure you've followed all instructions from Point 6. 'Starting the Exposure' above. Make sure that you opened the shutter slide for the exposure within 5 seconds of hearing the 'success' sound/seeing the flash. Make sure that the shutter was pulled all the way out. Make sure the tower had all 5 stages fully extended and locked, and that you removed the cradle cover before the exposure. If you're using the iPhone 6 or a larger tablet or Android operating device, the removable adaptor should also be removed so that your device covers the three rubber points fully. If the tower is not fully extended this could result in black border lines on the edges of your frame.

My photo turned out partially/completely white

Make sure the shutter slide was not left open after your device was removed. If your photo comes out partially white, make sure that your device is sitting snugly in the cradle. Do not remove the film pack from the Instant Lab Universal after you have ejected the protective darkslide until film pack is empty, as this will expose the top photo of the film pack. If you're using the iPhone 6 or a larger tablet or Android operating device, the removable adaptor should also be removed so that your device covers the three rubber points fully.

My photo turned out too light or with low contrast

Shield your photo from light during the development process. Make sure that photos are developed at 13 – 28°C (55 – 82°F). If processed below 13°C (55°F) photos are likely to turn light and colorless. Ensure the film type selected in the App matches the pack in the Instant Lab Universal. Alternatively choose a shorter exposure time in the App.

Note If your question hasn't been answered here, then please feel free to contact the Impossible Customer Support team.

My photo turned out too dark

Make sure that the film type selected in the App matches the film you're using inside the Instant Lab Universal.

My photo turned out blurry or fuzzy

Make sure all 5 stages of the tower of your Instant Lab Universal are fully extended and locked. If the tower sags in any spot this could cause the image to be out of focus. Make sure the lens is clean.

There are spots or marks on my photo

Do not squeeze a film pack as this may result in the film being damaged and you will lose effective parts of your photos. Always hold the pack by its edges. Do not bend or shake your photo during development. Do not touch or add pressure to the photo in the image area before it has fully developed. Carefully hold and handle the photo by the frame only. Make sure that the metal rollers of your Instant Lab Universal are clean (see 'Cleaning the Instant Lab Universal' above).

TROUBLESHOOTING & F.A.Q.

My photo changes its color or loses contrast after several weeks

Impossible photos should not be exposed to extreme humidity, high temperatures or direct sunlight for an extended period of time. Make sure you store your photos upright in a cool, dry place with 'room to breathe' until the frames have fully dried (between 1 – 2 weeks for Generation 1.0 film and 5 - 7 days for Generation 2.0). Please also refer to the film tip sheet printed on the inside of every Impossible film pack for detailed instructions regarding photo handling and storage.

CUSTOMER SUPPORT

The Impossible Customer Support Team is always more than happy to hear from you. Please get in touch using the contact details provided below.

For more detailed and up-to-date information, please visit:
the-impossible-project.com/lab

EUROPE/RoW

service@the-impossible-project.com
00.800.577.01.500

AMERICA/CANADA

usa@the-impossible-project.com
+1.212.219.3254

TECHNICAL SPECIFICATIONS

- The Instant Lab Universal is compatible with iPhone 4/4s/5/5s/5c/6/6 Plus, iPod Touch fifth generation and up, iPad Mini 2 and up, iPad 3 and up (including iPad Air).
- Compatible with the most popular Android-operating smartphones and tablets with high-resolution displays.
- For a full list of optimized and supported devices, visit the-impossible-project.com/instantlab or contact the Impossible Customer Support Team.
- The Instant Lab Universal requires high-resolution smartphones and

tablets (with approx. 300 PPI displays) using version 3 or higher of the Impossible Project App for iOS and Android. For a full list of compatible devices, visit the-impossible-project.com/instantlab. Alternatively, contact Customer Support:
service@the-impossible-project.com.

- Download for free from Google Play, the Apple App Store or head to the-impossible-project.com/app.
- Compatible with Impossible Color and B&W film for Polaroid™ 600 and SX-70 cameras, including Special Editions.
- Optical System: 4 element coated glass lens, wide-angle
- Micro-processor-controlled film processing unit
- Rechargeable Li-ion battery 7,4V / 2,33VAh(Wh)
- USB Power Adapter
- Compatible with Impossible Color and Impossible B&W Film
- International Patent Pending
- Dimensions: collapsed 150mm/5.9" long × 111mm/4.3" wide × 71mm/2.8" tall; extended 179mm/7" tall
- Weight: 650g/23oz (including adaptor and cover plate)